

We pump. You work. In a better way.

Euromacchine
PUMPING INNOVATION

AGRICULTURE

Pumping solutions range for contemporary agriculture needs in Irrigation and Manure sectors.



TRUE POWER COMES FROM GREAT EXPERIENCE.

We give practical responses to contemporary agriculture needs.

For more than forty years, we've been addressing always new pumping problems with a full range of Motor Pump Multifunctional Groups. Technological advancements to ensure **high-performance machines**, that combine **extensive customization capabilities** with the best components on the market and also innovative design **with functional solutions**. Yes, but there's more: our efficient machines guarantee remarkably reduced consumption for a great return on investment over time.

We understand your needs, and support your business.



INNOVATION

INNOVATIVE PRODUCTS

- Research & Development
- Design & Patent

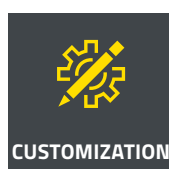

CUSTOMIZATION

MADE ON YOUR NEEDS

- Highly customized solutions
- Tailor made products

OFFICIAL DISTRIBUTOR of



CORNELL PUMPS



RIVERSCREEN FILTERS

IRRIGATION RANGE



MOTOPOMPA



LAMPO AG



CAIMANO



MOTOPOMPA COMBI



MOTOPOMPA SR

MANURE MOTOPOMPA RANGE



CORNELL SERIES



BAUER SERIES



DODA SERIES

CORNELL PUMPS. EFFICIENT BY DESIGN.



Cornell has been producing pumps for agriculture since 1946. Over the years, Cornell engineers have continuously improved pump design and functionality. Cornell pumps come with unique features such as **Cycloseal**, **Run-Dry®**, and **Redi-Prime®**, making them capable of handling even the most challenging scenarios. With an **efficiency rating up to 89%**, Cornell pumps are widely recognized as one of the best choices when it comes to agriculture pumps.

Cornell's extensive dealers network and highly stocked warehouses ensure prompt and **reliable support** for our customers.

The distinctive muscular frame of Cornell's agricultural pumps is what best represents their superior quality.



LESS WEAR

- Less maintenance
- Less parts
- Less downtime

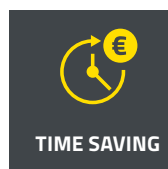

EFFICIENCY

- Efficiency up to 89%
- Less fuel consumption
- Oversized shaft & bearings



IRRIGATION

CLEAR LIQUID SERIES

- Hard construction
- Wear resistant shaft
- Oversized bearings
- High-efficiency, fully-machined impellers
- Efficiency up to 89%
- Heavy walled castings



CAPACITY

Up to 1200 m³/h



HEAD

Up to 120 m



SOLIDS HANDLING

Up to 25 mm – 1"



MANURE

N SOLIDS HANDLING AND MP SERIES

- Designed to break up clogs and prevent ragging
- Hardened for long life
- Shaped to minimize flow restrictions
- It saves labor and downtime required to clean out clogs
- Breaks up "flushable" wipes and other materials in municipal applications
- Breaks up clumps of straw in manure applications



CAPACITY

Up to 2000 m³/h



HEAD

Up to 200 m



SOLIDS HANDLING

Up to 114 mm – 4.5"

CORNELL PUMPS EXCLUSIVE BENEFITS



REDI PRIME®

Fully automatic pump priming and re-priming cycles



RUN DRY™

Seal lubrication and cooling system preventing from running without liquid



CYCLOSEAL®

Dished backplate creating pressure gradients to remove solids

CORNELL PUMPS FOR IRRIGATION. CLEAR LIQUID AND MX PUMPS.



Cornell's **Clear Liquid pumps** are renowned for their **durability, reliability, and high efficiency**. The **MX pumps** are specifically designed to handle high-head applications with long service life and suction lift capabilities.

These pumps are used in various **Agricultural, Industrial, and Municipal** applications and come in Close-Coupled, SAE Engine Mounted, Horizontal, and Vertical configurations.



CORNELL CLEAR LIQUID PUMPS BENEFITS

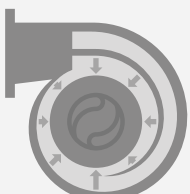

DOUBLE VOLUTE

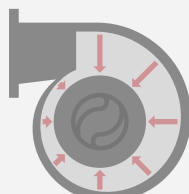

SINGLE VOLUTE

DOUBLE VOLUTE

The double volute system effectively balances forces within the pump to reduce radial load, shaft deflection and fatigue. This eliminates shaft breakage and extends the service life of mechanical seals, wear rings and bearings.

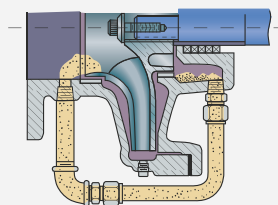

HYDRAULIC BALANCE LINE

Cornell's external hydraulic balance line equalizes pressure between the impeller hub area and the pump suction to reduce axial loading acting on the impeller, shaft and bearings.



CLEAR LIQUID PUMPS

H - R SERIES



FEATURES & BENEFITS

Cornell clear liquid centrifugal pumps are designed to deliver best-in-class efficiency. Depending on operating hours, fuel, and horsepower required, you can save thousands per year in energy costs.



CAPACITY

Up to 1600 m³/h



PRESSURE

Up to 150 m



SOLIDS HANDLING

32 mm – 1,25"

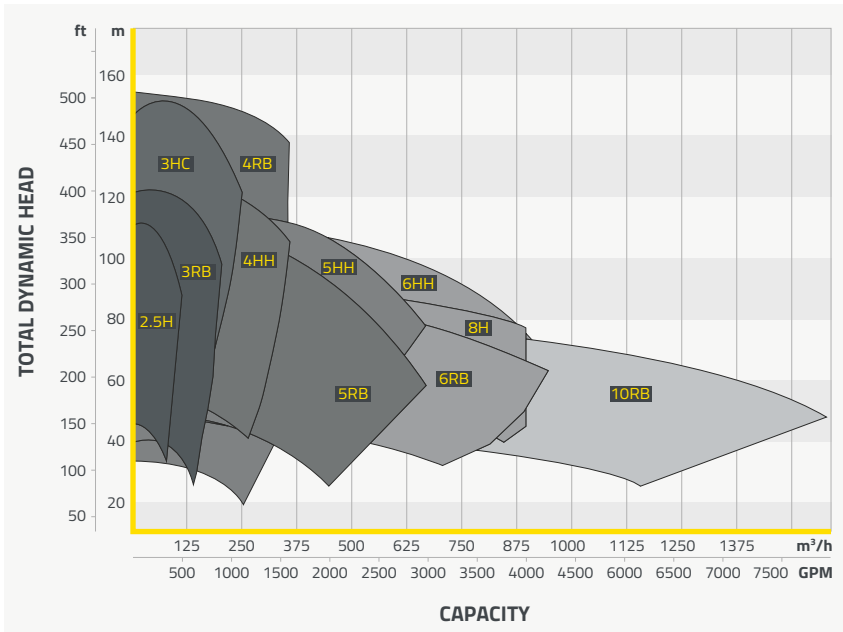

HIGH HEAD PUMPS

MX SERIES



FEATURES & BENEFITS

Designed to handle high head applications while providing a long service life, the MX SERIES pumps have multi-vane, enclosed CA6NM stainless steel impellers designed for industry leading efficiency of up to 78%.



CAPACITY

Up to 1800 m³/h



PRESSURE

Up to 275 m



SOLIDS HANDLING

61 mm – 2,38"

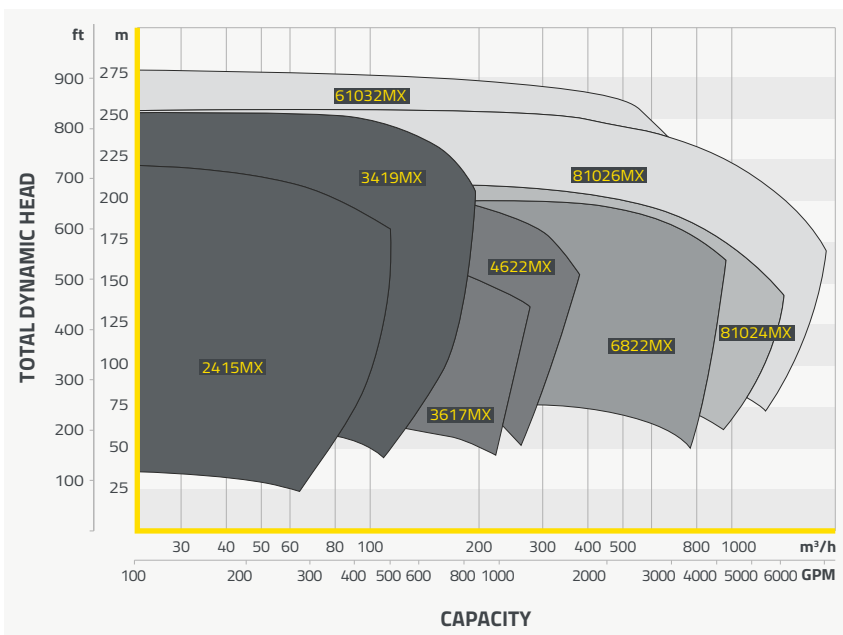

CORNELL PUMPS FOR MANURE. SOLIDS HANDLING AND MP SERIES.



Cornell pumps, including **N Series solids handling pumps** and **MP Series pumps**, play a pivotal role in the **manure sector**.

Specifically designed for the demanding task of managing animal waste, these pumps are engineered to handle **solid-laden liquids** and **viscous materials** commonly found in manure.



CORNELL MANURE PUMPS IMPELLER BENEFITS



ENCLOSED

Large spherical solids pass through the pump while offering optimal head and efficiency.



SEMI-OPEN

Cutting action allows the semi-open impeller to handle the worst slurries at high heads.



DELTA

Vortices are created to allow solids pass through the impeller. Larger solids are broken up.



BLADE CUTTER

Blade cutter impeller, designed to break up the most aggressive clogs & ragging.



SOLIDS HANDLING PUMPS

N SERIES

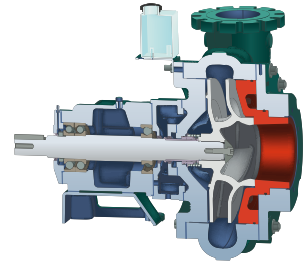

FEATURES & BENEFITS

Cornell has been producing solids handling pumps since the 1950's, offering a wide range, from 3" to 24" discharge size, to handle the toughest solids applications. The N series fill the need of medium-duty solids handling capabilities, with efficiency up to 82%.

CAPACITY
Up to 2000 m³/h

PRESSURE
Up to 175 m

SOLIDS HANDLING
121 mm – 4,75"

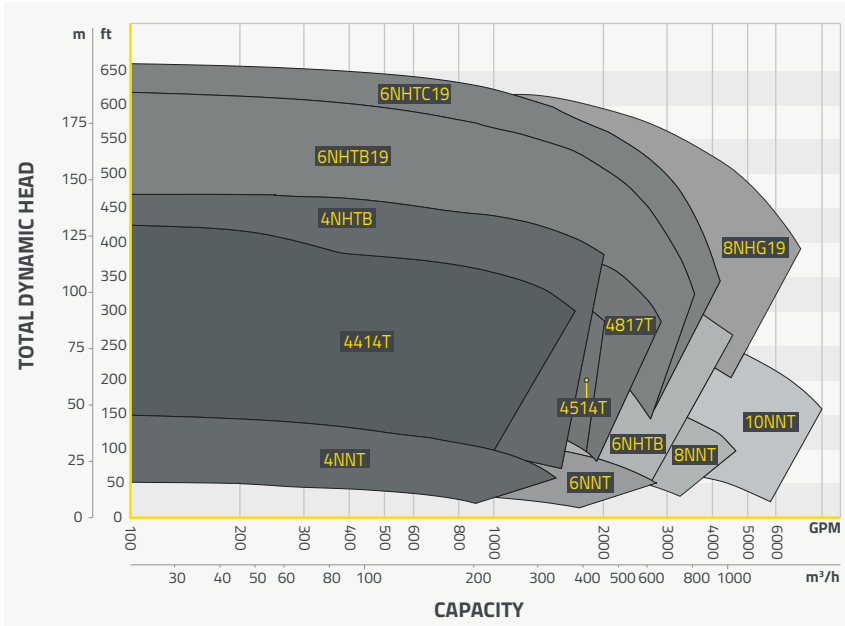

COARSE ABRASIVE PUMPS

MP SERIES

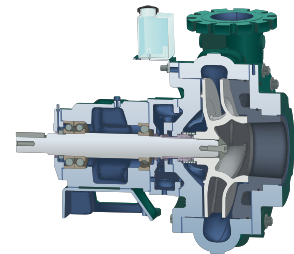

FEATURES & BENEFITS

MP series are built to withstand harsh conditions and handle coarse abrasives in slurry pumping applications. Unique pushed-out rectangular design with oversize shafts, thick volutes, and high-chrome white iron impellers for longer service life.

CAPACITY
Up to 1600 m³/h

PRESSURE
Up to 200 m

SOLIDS HANDLING
32 mm – 1,25"

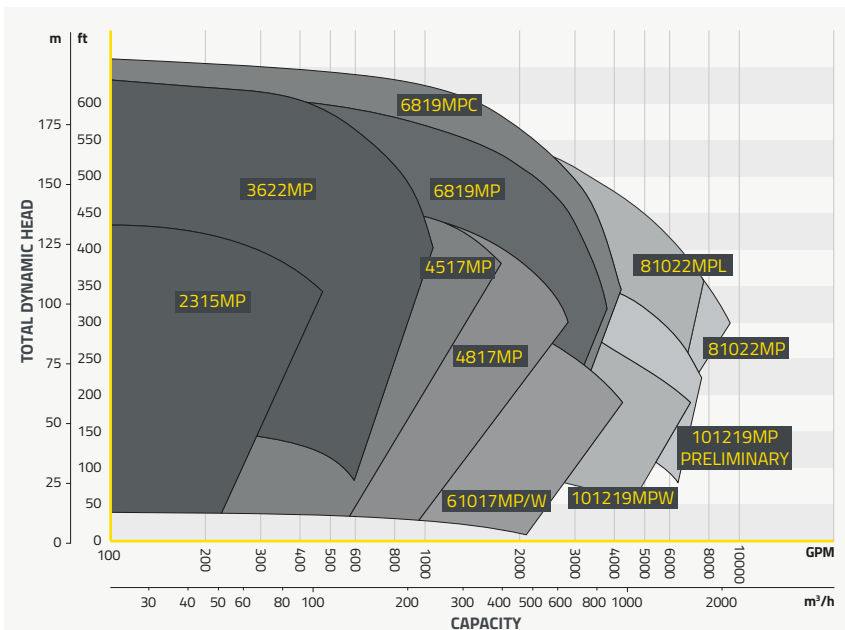

RIVERSCREEN™

A DEPENDABLE WATER SUPPLY SELF-CLEANING OPERATION.

INTERNATIONAL
RIVERSCREEN
DISTRIBUTOR

A **rotating water-driven self-cleaning screen** that dependably delivers good water from as little as **120 mm depth**. The ideal solution for the operation depending upon **river** or **canal** water sources for pivot irrigation systems. RIVERSCREEN is built for shallow water pumping, preventing **sand problems**. Low maintenance operation. Standard on all Riverscreens is **#10 304 stainless steel mesh (up to 120)**. Riverscreen filter works great even in **livestock lagoons**.



FISH FRIENDLY

Riverscreen is fully designed to avoid from pumping small fishes and eels (2mm) and preserve environment.

TECHNICAL SPECS



MIN. WATER DEPTH
From 120 mm



PUMP FLOW RATE
From 40 to 2000 m³/h



FILTRATION
From 8 to 200 mesh



SUCTION DIAMETER
From 4" to 12"

FEATURES

- ✓ High water filtration
- ✓ Prevent sand problems
- ✓ Slow moving currents
- ✓ Low-pressure nozzles
- ✓ Low maintenance operation
- ✓ Ideal for livestock lagoons

FEATURES

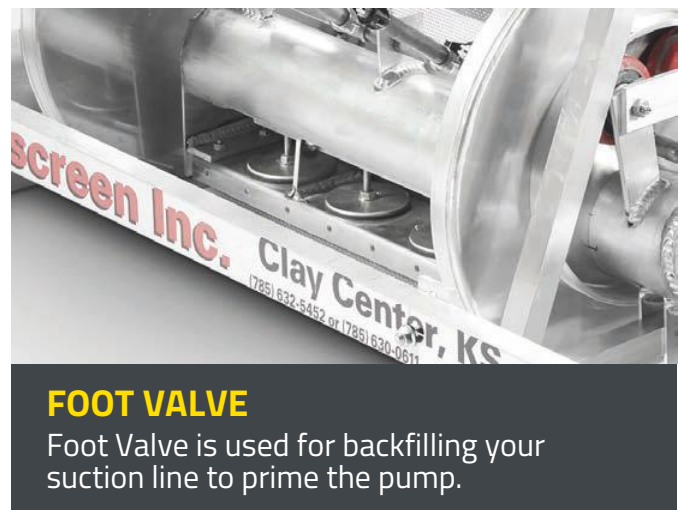

PARTS

- 1 Motor drive (OPT)
- 2 Water driven PowerDrive
- 3 Screen drum (Special mesh available on gravity model)
- 4 Self-cleaning spray bar
- 5 Sturdy aluminium frame
- 6 Aluminium pontoons



STANDARD RIVERSCREEN



Applications

This model is used to filter water when irrigating with a standard machine.



MIN. WATER DEPTH
From 120 mm



FILTRATION
From 8 to 18 mesh

MODELS	MAX FLOW		PONTOON		
	Sizes [inch]	[l/min]	[m³/h]	N°	Ø [inch]
4"	1000	60	3+1	6"	0.7
6"	3000	180	3+1	10"	2.0
8"	4750	285	3+1	10"	2.4
10"	9500	570	3+1	10"	3.0
12"	15000	900	4+1	10"	3.0

LINEAR RIVERSCREEN



MIN. WATER DEPTH
From 120 mm



FILTRATION
From 8 to 12 mesh



MOTOR DRIVE included
Three-phase or 12 V

Applications

This model is used to filter water when irrigating with a linear machine.

MODELS	MAX FLOW	
	Sizes [inch]	[l/min]
6"	3000	180
8"	4750	285
12"	15000	900

GRAVITY RIVERSCREEN



MIN. WATER DEPTH

From 500 mm



FILTRATION

From 8 to 200 mesh (74 µm)



MOTOR DRIVE included

Three-phase or 12 V

Applications

This model is used when a high water filtration is needed or when the pump is under head (positive suction).

MODELS Sizes [inch]	MAX FLOW	
	12 Mesh m³/h	300 Mesh m³/h
4"	60	30
6"	180	90
8"	285	143
12"	900	450



IDEAL FOR DRIP IRRIGATION



STANDARD RIVERSCREEN MEASUREMENTS 4 floating pontoons version

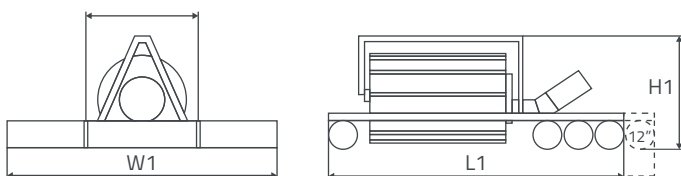

Sizes [inch]	L1 [mm]	W1 [mm]	H1 [mm]	Weight [Kg]
4"	1525	660	1075	50
6"	2337	1829	1075	84
8"	2667	2438	1075	105
10"	2667	3048	1075	120
12"	3000	3048	1075	130

MOTOPOMPA SERIES FOR IRRIGATION. CUSTOM SOLUTIONS FOR EVERY TYPE OF FLOW.

Euromacchine offers a wide range of pumps that meet, or even exceed, optimum efficiency standards. Depending on operating hours, fuel and horsepower required, this is a huge money saver each year in terms of energy costs.



d MOTOPOMPA DIESEL POWERED

A diesel pump unit that is environmentally friendly and meets all EU emissions standards while maintaining optimal performance in the field.



e MOTOPOMPA FULL ELECTRIC

An electric pumping station that guarantees maximum efficiency, energy savings and long-lasting performance. It produces minimal noise and zero emissions, it also requires low maintenance and offers maximum reliability.



VARIETY

FOR ALL USES

- Many configurations
- Many optionals
- Many prime systems



CUSTOMIZATION

MADE ON YOUR NEEDS

- Customizable for any type of need

PUMP SELECTION

CORNELL

Cornell centrifugal pumps are the most powerful variety of flow and pressure combinations to meet the needs of your irrigation clear water pumping operations.



PUMP FLOW RATE
Up to 1200 m³/h



PRESSURE
from 30 to 200 m

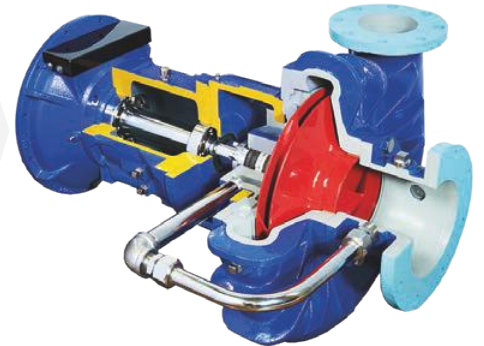

ROVATTI

Rovatti pumps offer extensive pumping possibilities along with high efficiency, robust construction and reliability for small, medium and high pressures & flow rates.



PUMP FLOW RATE
Up to 500 m³/h



PRESSURE
Up to 140 m



CAPRARI

Caprari pumps are suitable for medium performance both with single and multistage diesel pump units. Designed for agricultural irrigation applications and everything related to pumping non-corrosive clear water.



PUMP FLOW RATE
up to 250 m³/h



PRESSURE
Up to 140 m



APPLICATIONS



MUNICIPAL



MINING



IRRIGATION



OIL & GAS



CONSTRUCTION



DRILLING



INDUSTRY
& RENTAL



EMERGENCY



MANURE

PUMP SET FEATURES

d-MOTOPOMPA SUPER SILENT - TRAILER

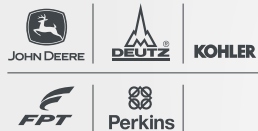

TANK
Up to 1.000 l



VERSIONS AND CONFIGURATIONS

VERSION	A	B	C	D
	STATIONARY	FORK LIFT	LIFTING HOOK	TRAILER
CONFIGURATION	1	2	3	4
	OPEN	ROOF	SIDE PROTECTIONS	SUPER SILENT

PUMP FEATURES

e-MOTOPOMPA OPEN - STATIONARY



ABB | SIEMENS



ENERGONICA | SANTERNO | Danfoss

Schneider Electric



PRIMING SYSTEMS



REDI PRIME®

Only for Cornell Pumps



SUPERTANK

Automatic or Manual



E-VACUUM

Available in 12 or 400 V



E-SELF

Available in 12 or 400 V



PLUTO - Kirpy

Manual version



PAM - Hand Pump

Manual version



MOTOPOMPA RANGE

SIZE S | < 50 m³/h



PRESSURE
Up to 100 m
 
rovatti



SIZE M | < 250 m³/h



PRESSURE
Up to 140 m
 
CORNELL
rovatti
caprari

SIZE L | < 500 m³/h



PRESSURE
Up to 140 m
 
CORNELL
rovatti

SIZE XL | < 1000 m³/h



PRESSURE
Up to 200 m
 
CORNELL

CASE STUDIES



LAMPO AG. MANY FUNCTIONS IN A SINGLE MACHINE.

LAMPO patented multifunctional unit is based on a revolutionary concept: a **generating set** which, thanks to the **electrical panel** equipped with an **inverter**, drives an **electric pump** (submersible or centrifugal) with the possibility of regulating its flow rate and pressure. Lampo Green represents the most versatile solution in irrigation, guaranteeing water draft from wells with minimum diameters of **180 mm** with depths up to **40 m** and pumps from **25 to 500 m³/h**. **1000 l tank frame** and **SUPER SILENT** canopy are standard.



LAMPO AG
DOUBLE PUMP



PRIME SUBMERSIBLE PUMP

4" or 6" Submersible Pump with max depth of 40 m.



rovatti pompe



VERTICAL BOOSTER

Multistage Electric Pump to reach high pressure in difficult conditions.



rovatti pompe



GEN SET

Not only an irrigation unit, Lampo is 365 days / year a gen set with mono and three-phase sockets.

**LAMPO AG
SUBMERSIBLE PUMP**



KEYPAD

The easiest way to drop and lift up the submersible pump into the well.



INVERTER

The best way to manage and properly set the electric pump performance.



TECHNICAL SPECS



PRESSURE
From 30 to 160 m



CAPACITY
Up to 500 m³/h



WELL SIZE
Minimum 230 mm



TANK
1000 l



GENERATOR POWER
Up to 200 kVA



WELL DEPTH
Up to 50 m

ALL AVAILABLE VERSIONS



LAMPO AG / No Pump



LAMPO AG / Submersible



LAMPO AG / Horizontal Pump



LAMPO AG / Double Pump



CASE STUDIES



LAMPO AG DOUBLE PUMP



LAMPO AG & CORNELL



LAMPO AG & 2 PIVOT



LAMPO AG WITH SUPER TANK



LAMPO AG & RIVERSCREEN



LAMPO AG & 2 PIVOTS

CAIMANO. VERTICAL MOUNT CORNELL RIVERSCREEN.

An innovative floating pump station matched with a Riverscreen self cleaning filter and a high efficiency Cornell vertical electric motor pump unit. Directly fed by the pumped liquid, it ensures an immediate auto-priming of the irrigation system. Lightweight thermoformed plastic pontoons provide flotation to the entire unit.

Caimano is the ideal irrigation solution that can be operated in a range of water sources such as reservoirs, rivers, streams, dams, canals and be successfully used on pumping systems including drip irrigation, pivots and in all cases where suction height is a topic issue to be solved.



1

ALL IN ONE

ALL IN ONE

- Pumping Station
- Cleaning Filter
- Floating Unit



ULTIMATE SOLUTION

TOPIC SPECS

- Easy access & low maintenance
- Long run efficiency

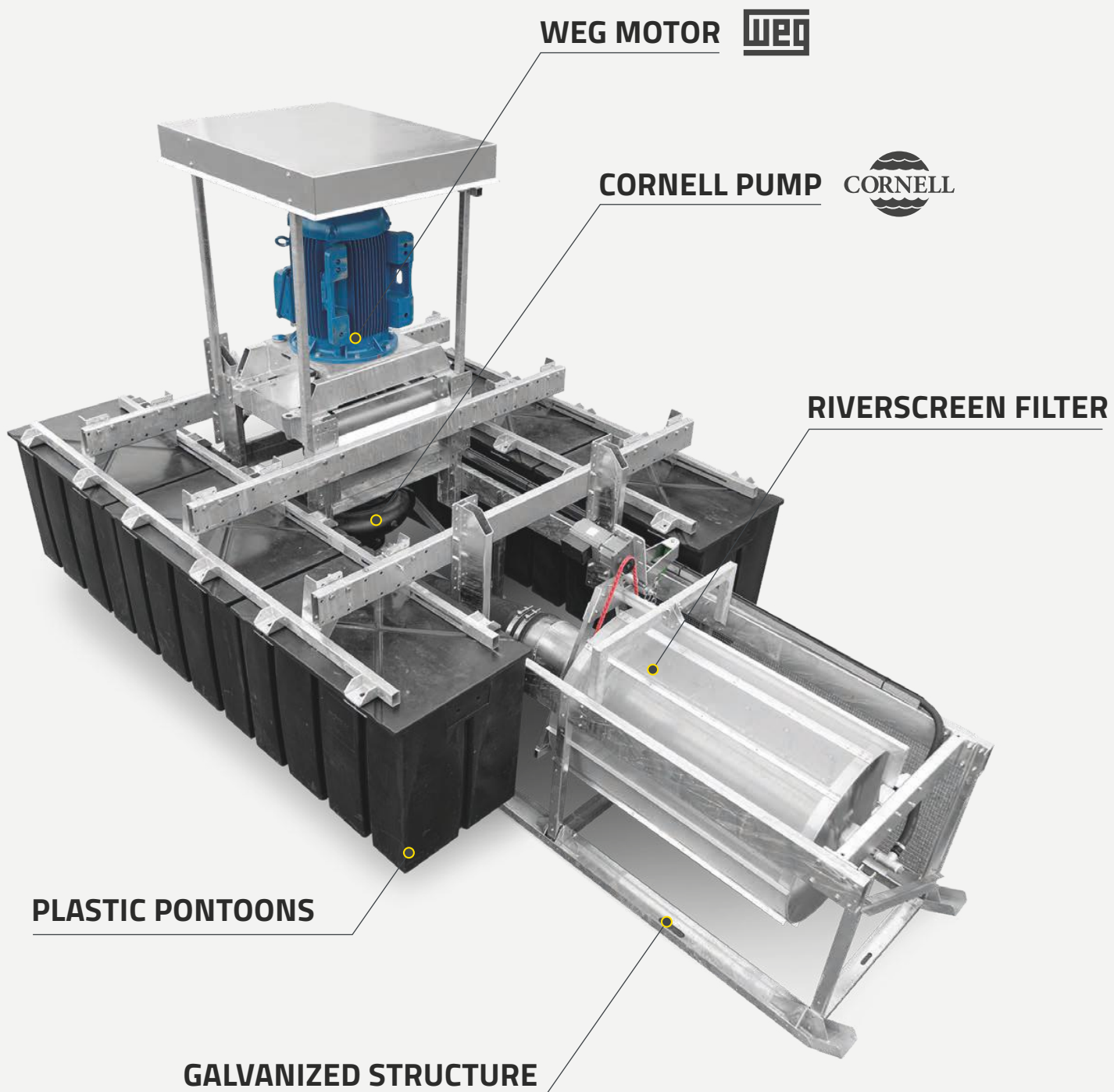

TECHNICAL SPECS



CAPACITY
Up to 1300 m³/h



PRESSURE
Up to 70 m



FILTRATION
From 8 to 200 mesh



SUCTION DIAMETER
From 4" to 12"

APPLICATIONS

- ✓ PIVOT
- ✓ FROST IRRIGATION
- ✓ DRIP IRRIGATION
- ✓ RESERVOIR SOLUTIONS

CAIMANO. PARALLEL VERSION.



CLEAR LIQUID PUMPS

H - R SERIES

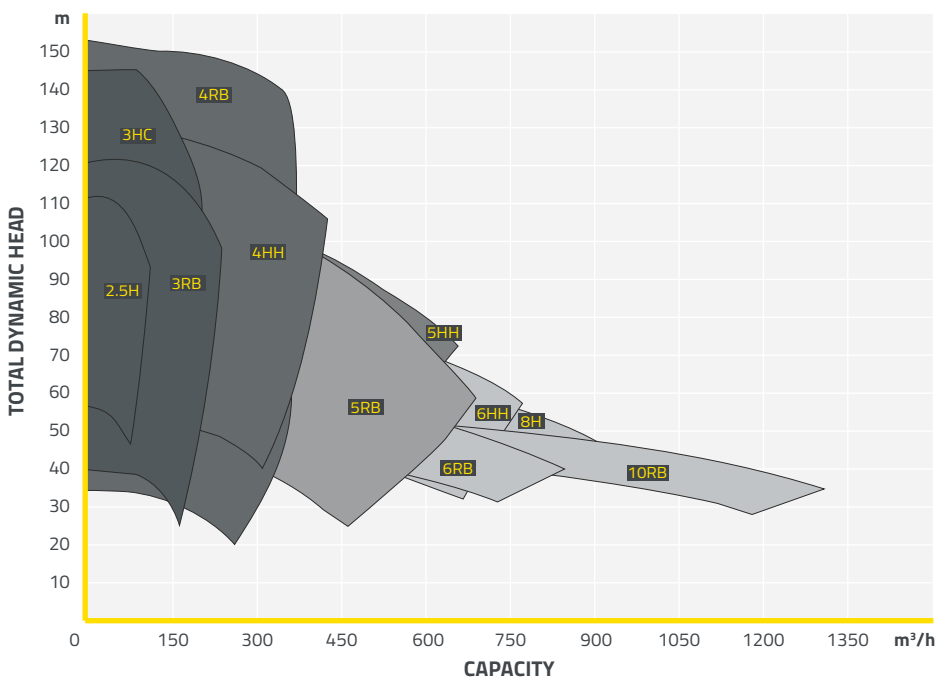

Features & Benefits

Cornell clear liquid pumps in Vertical position with WEG electric motor from 37 to 160 kW.

Available in RB and H Series.



CAPACITY

Up to 1.300 m³/h



PRESSURE

Up to 150 m



SOLIDS HANDLING

32 mm – 1,25"

ROMANIA PROJECT

SOLUTION: 2 CAIMANO CORNELL 5HH + WEG 75 kW

CAPACITY: 2x300 m³/h

PRESSURE: 60 m



FRANCE PROJECT

SOLUTION: 2 CAIMANO CORNELL 5HH + WEG 55 kW+ 2 LAMPO UNITS

CAPACITY: 2x350 m³/h

PRESSURE: 40 m



MOTOPOMPA COMBI SERIES. FOR LINEAR & PIVOT IRRIGATION SYSTEMS.

A linear or pivot irrigation system needs specifically designed features for this type of use. The main element that distinguishes this series is being able to work with an always running alternator, without necessarily using the pump. This is possible through a device allowing the detachment of the pump from the engine or, as a better alternative, with the revolutionary Run Dry system which does not require a clutch as it lubricates the pump even in the absence of water.

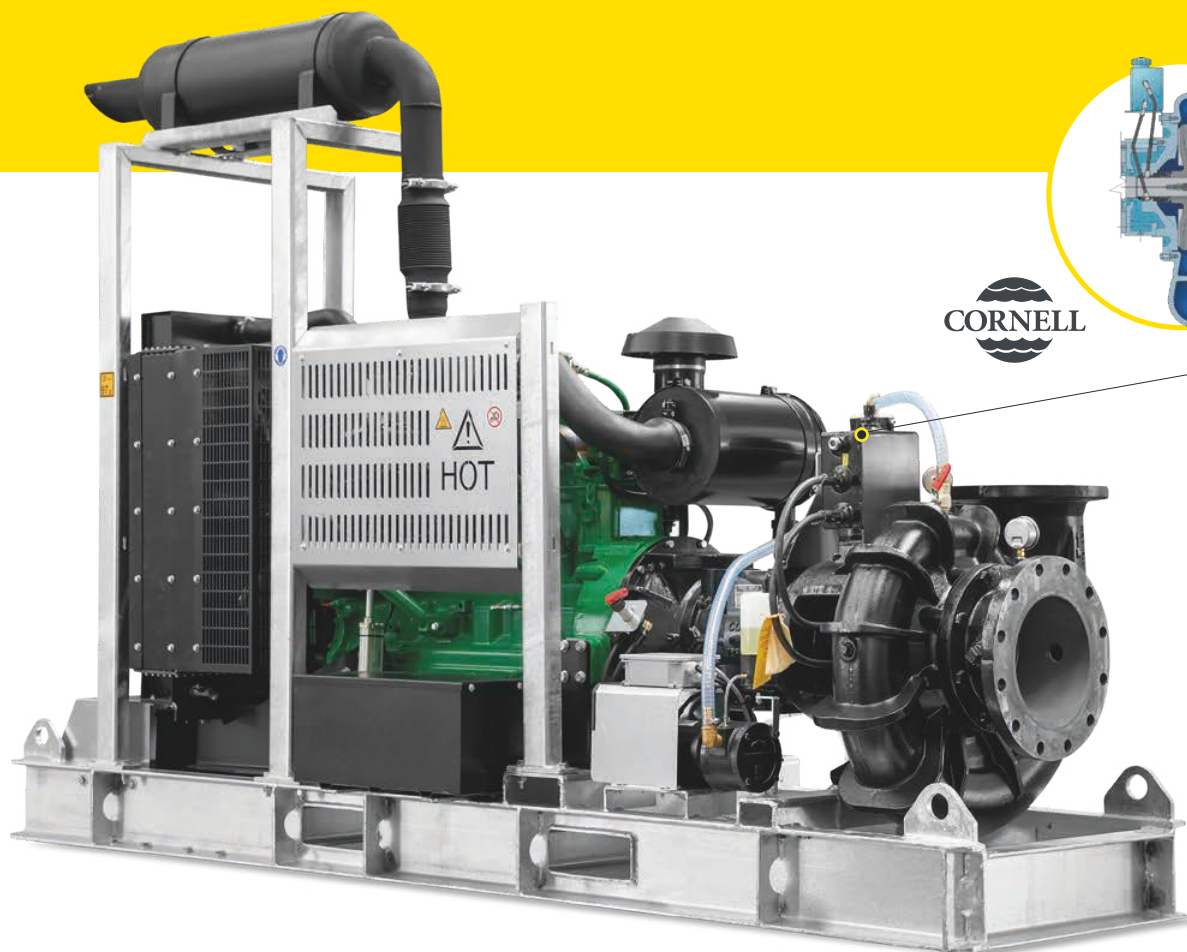

SPECIAL OPERATIVE MODE

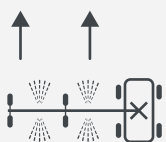

SUMMER MODE

The summer mode allows to have electricity and active pumping at the same time.

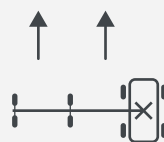

WINTER MODE

The winter mode refers only to the movement of the pivot having the centrifugal pump disconnected.

TECHNICAL SPECS



CAPACITY

Up to 1200 m³/h



PRESSURE

Up to 50 m



NPSHr

Low NPSHr value



ALTERNATOR

MeccAlte - Marathon



GENERATOR POWER

From 10 to 40 kW



FREQUENCY / VOLTAGE

50Hz - 400 V or 60Hz - 460V



POWER TAKE OFFS

Manual or automatic Twin-disc clutch to disconnect the pump from the engine in winter mode.



ALTERNATOR FOR LINEAR

Available in 50/60 Hz and 400/460 V. Power from 10 to 40 kW

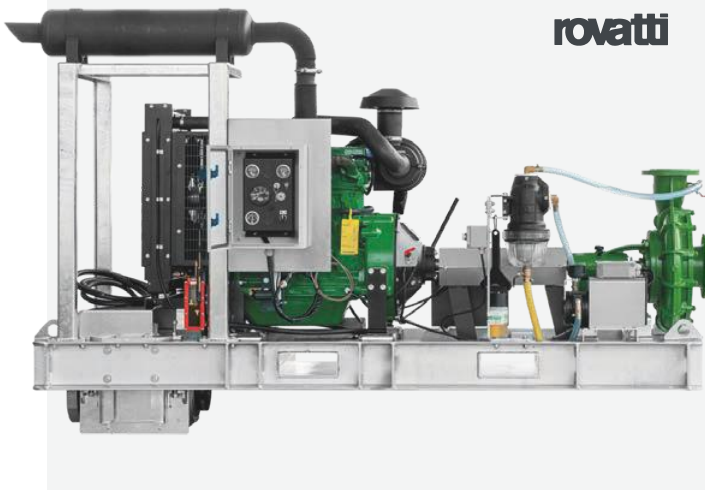

rovatti



Euromacchine

VERSION

A	B	D
NO TANK	TANK FRAME	TRAILER

CONFIGURATION

2	5
ROOF	SUPER SILENT

MOTOPOMPA "SR" SERIES. A TRUE REVOLUTION.



The patented "SR" series sees the diesel pump unit and the Lampo deprived of the radiator thanks to our Supertank priming system which now performs two functions: priming of the pump and cooling of the engine. The water contained within the tank and a heat exchanger successfully cool the engine along with other benefits. The greater efficiency given by the energy savings due to the absence of the radiator and the consequent drastic reduction noise make this multifunctional unit a truly avant-garde product, thus making it the future of water pumping.



SR DIESEL PUMP UNIT



LAMPO SR KILLER



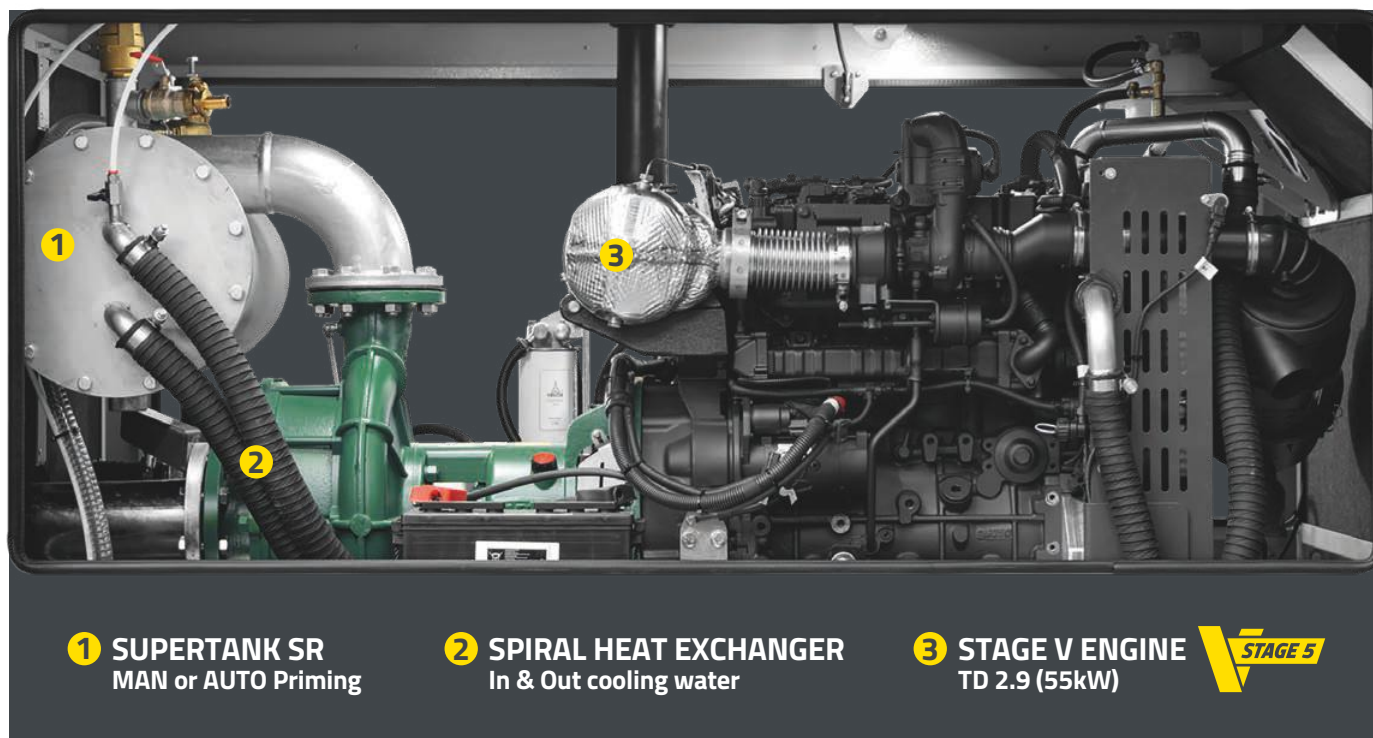

TWO FUNCTIONS

- 1 Manual or Automatic pump priming.
- 2 The heat exchanger inside the supertank is cooled by the water inside.

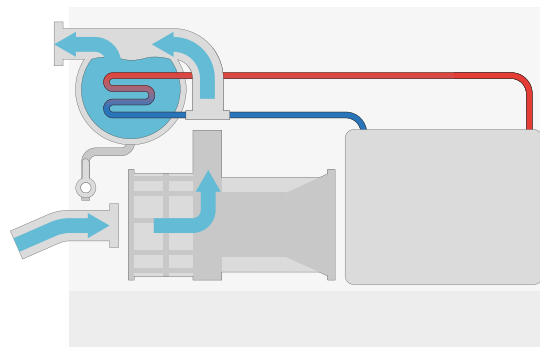
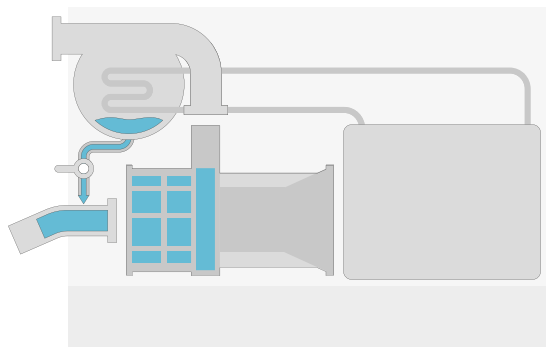

TECHNICAL SPECS



PRESSURE
From 60 to 140 m



PUMP FLOW RATE
From 40 to 200 m³/h



JOHN DEERE

DEUTZ

FPT



rovatti pompe

caprari
pumping power

FEATURES

- ✓ Lower fuel consumption
- ✓ Less absorbed power
- ✓ Lower noise
- ✓ Compact dimensions
- ✓ Low maintenance
- ✓ Less hassle
- ✓ Less emission
- ✓ Manual or automatic filling system

CORNELL MANURE PUMPS. MANURE PUMPING AND DISTRIBUTION.



Cornell pumps, including **N Series solids handling pumps** and **MP Series pumps**, play a pivotal role in the **manure sector**.

Specifically designed for the demanding task of managing animal waste, these pumps are engineered to handle **solid-laden liquids** and **viscous materials** commonly found in manure.



TECHNICAL SPECS



CAPACITY

Up to 2000 m³/h



PRESSURE

Up to 160 m



SUCTION FLANGE

Up to DN300 - 12"



DISCHARGE FLANGE

Up to DN250 - 10"

APPLICATIONS

- ✓ Hose reel machine
- ✓ Tankers
- ✓ Dribble bars
- ✓ Umbilical systems
- ✓ Biogas plants

PUMP SELECTION

TRACTOR

4NHTB Cornell pump with gear box multiplier 1:0,5 to reach 2.000 Rpm of the pump.



PUMP FLOW RATE
up to 360 m³/h



PRESSURE
from 30 to 140 m



ELECTRIC



Electric Cornell Pump suitable for VFD (Inverter) control panel.



PUMP FLOW RATE
up to 2000 m³/h



PRESSURE
from 30 to 160 m



DIESEL



Diesel Cornell Pump available with a wide range of engine Brands and different Configurations and Versions.



PUMP FLOW RATE
up to 2000 m³/h



PRESSURE
from 30 to 160 m



CORNELL PUMPS EXCLUSIVE BENEFITS



REDI PRIME®

Fully automatic pump priming and re-priming cycles



RUN DRY™

Seal lubrication and cooling system protecting from running without liquid



CYCLOSEAL®

Dished backplate creating pressure gradients to remove solids



BLADE CUTTER

Blade cutter impeller, designed to break up the most aggressive clogs & ragging

N - SOLIDS HANDLING - PUMPS. FOR MANURE TRANSFER, INJECTION & SPREADING.

Cornell offers over 60 models of heavy duty Solids Handling Pumps for the toughest slurry applications.

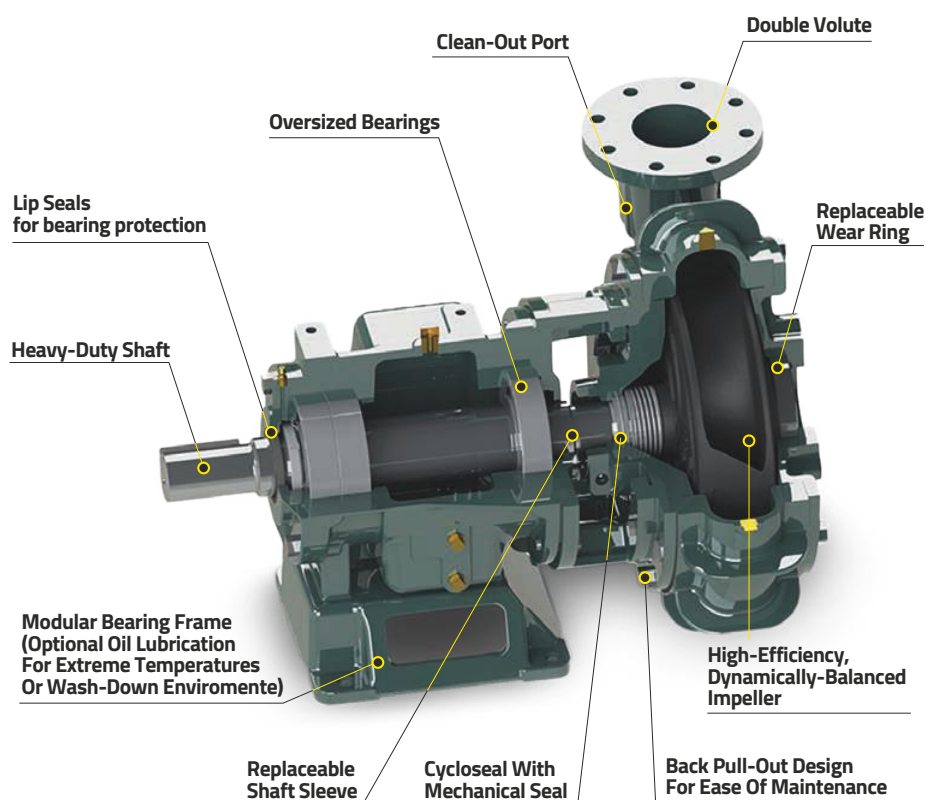

TECHNICAL SPECS



CAPACITY
Up to 1814 m³/h



PRESSURE
160 m



SOLIDS HANDLING
85,8 mm - 3,38"



DISCHARGE SIZE
100 - 254 mm



IMPELLER
Enclosed, Semi-open or Delta

CURVES

CURVE NO:	Speed	Impeller Dia.	Style	Solids Dia.	N _g	Suction	Discharge	No. Vanes
4NHTBVA	VARIOUS	17.5"	ENCLOSED	3.00"	980	5"	4"	2

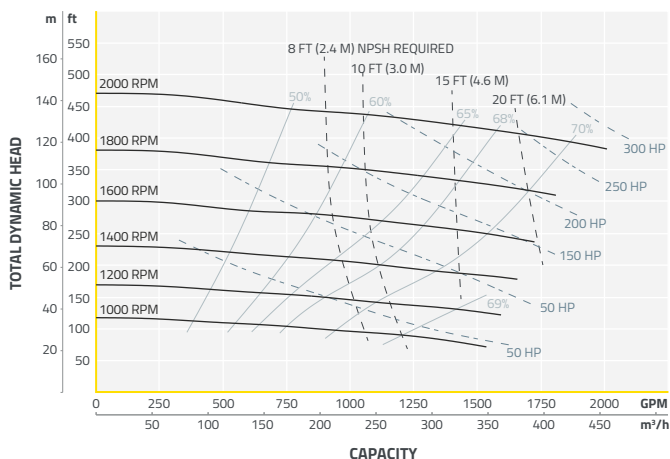

CURVE NO:	Speed	Impeller Dia.	Style	Volute	Solids Dia.	N _g	Suction	Discharge	No. Vanes
4NHTB19VA	VARIOUS	19.5"	ENCLOSED	SINGLE	2.00"	875	8"	4"	2

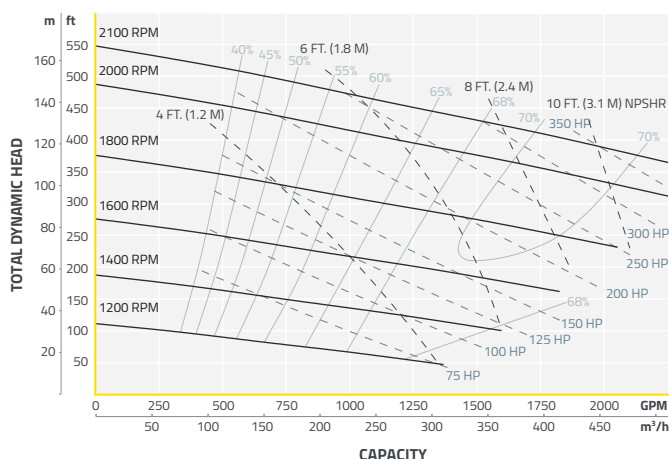

MP PUMPS. DESIGNED FOR COARSE ABRASIVE LIQUIDS.

The MP series offers exceptional wear resistance for reduced maintenance and long life in harsh environments.

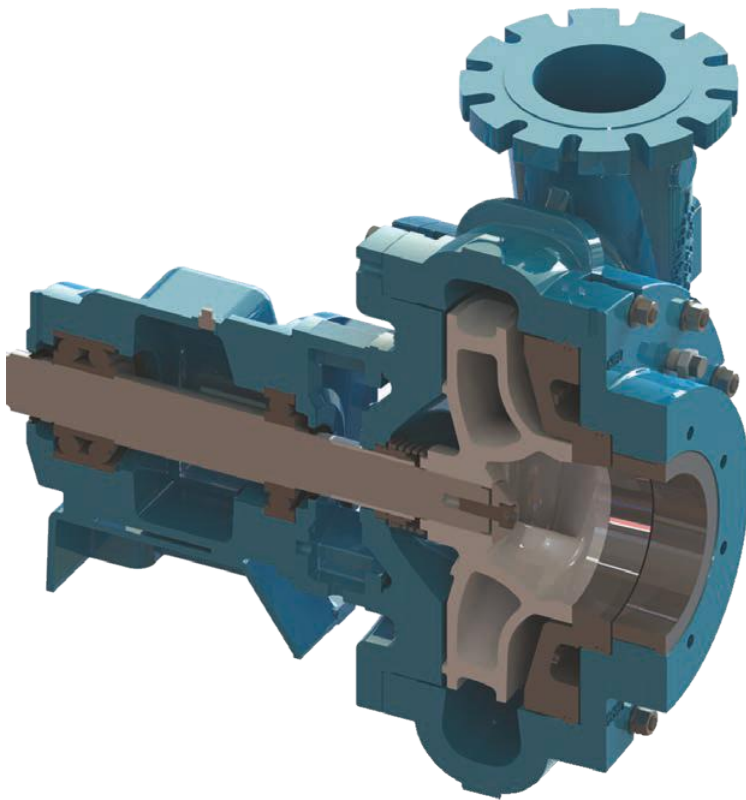

TECHNICAL SPECS



CAPACITY
Up to 2044 m³/h



PRESSURE
198 m



SOLIDS HANDLING
101 mm - 3,98"



DISCHARGE SIZE
50 - 254 mm



IMPELLER
Enclosed

CURVES

CURVE NO:	Speed	Impeller Dia.	Style	Volute	Solids Dia.	N _s	Suction	Discharge	No. Vanes
4817MPVA	VARIOUS	17.5"	ENCLOSED	SINGLE	3.00"	1181	8"	4"	2

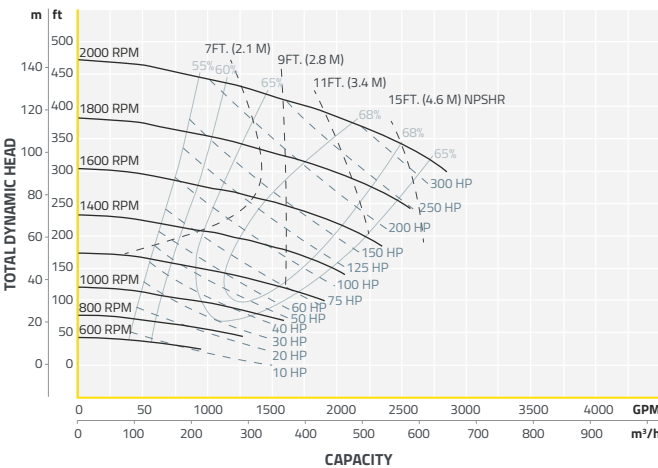

CURVE NO:	Speed	Impeller Dia.	Style	Volute	Solids Dia.	N _s	Suction	Discharge	No. Vanes
6819MPCVA	VARIOUS	19.5"	ENCLOSED	SINGLE	3.00"	1080	8"	6"	2

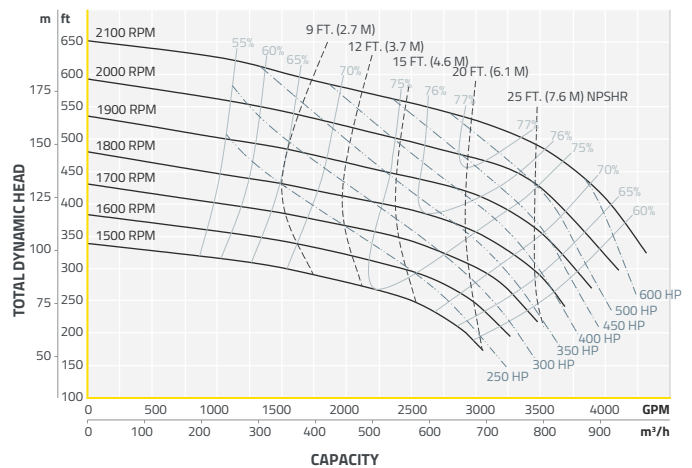

BAUER PUMPS. HIGH PRESSURE PUMPS WITH CUTTING DEVICE.



The gear and pedestal pumps from BAUER are characterized by their excellent comminution effect and large delivery heights. The MAGNUM SX series from BAUER impresses with its excellent shredding effect and considerable pump heights. These pumps are available in three (3) versions:

- **SX 2600** with pedestal mount for electric driven motors
- **SX 2000** with heavy-duty gearbox for diesel engines
- **SX 1000** with heavy-duty gearbox as tractor pumps

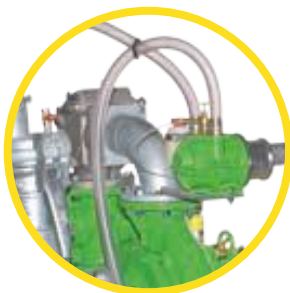

SELF-PRIMER

Mechanical, hydraulic or electro-mechanical execution



AUTO PRESSURE REGULATION

To manage working conditions



IMPELLER

High-grade casting, maximum wear-resistance

MAGNUM SX MODELS



FEATURES

- ✔ **Pump Housing:** Of special design, ensures unobstructed delivery of viscous liquids.
- ✔ **Cutting blades:** Easily adjustable to maintain the ideal cutting gap, draw cut.
- ✔ **Suction flange:** Ensures enormous suction capacity, avoids turbulences.
- ✔ **Shaft sealing:** Of industrial standard, double-acting mechanical seal with oil tank.
- ✔ **Pump shaft and bearing:** Widely dimensioned.
- ✔ **Gearbox:** Of compact industrial design.

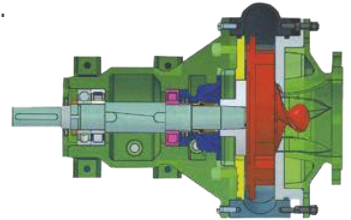

CURVES

PRESSURE AND CAPACITY RANGES

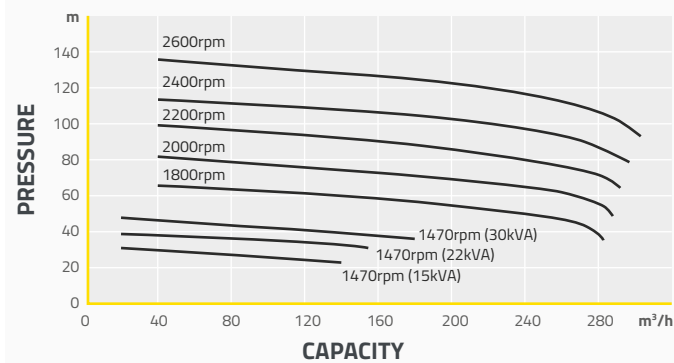

POWER AND CAPACITY RANGES

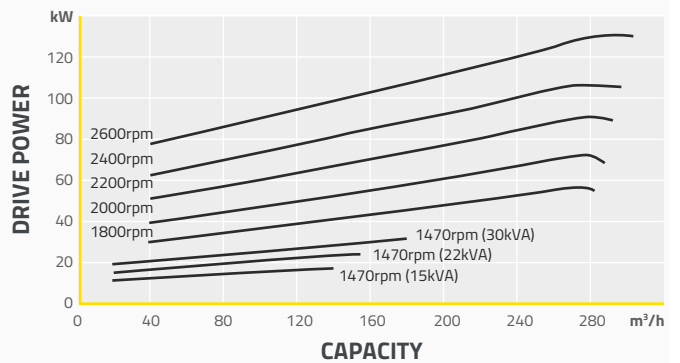

DODA PUMPS. AFI HORIZONTAL CHOPPER PUMPS (TRACTOR OR ENGINE DRIVEN)



These pumps are designed for the treatment of livestock slurry and the processing waste of industrial plants. It is suitable for very thick manure.

These thick part present in liquid manure is shredded by means of a double chopping mechanism, with which AFI machine are standard equipped.

They are available in a wide range of models with different performances and powers and can be driven by Tractor, electric as well as hydraulic motors.



PATENTED CHOPPING SYSTEM

Consisting of two static and one rotating chopper blade.



POWER PRIMER SYSTEM

Belt, hydraulic, 12 volt and three phase electric motor drive options.



INTERNAL CHECK VALVE

Internal check valve mounted on the intake (suction) cone.

AFI MODELS



DODA AFI HD
TRACTOR UNIT



AFI IV SERIES
DIESEL ENGINE



AFI PD SERIES
ELECTRIC MOTOR

FEATURES

- ✔ 1 Pump body, impeller, suction bell and pump support in antishock and anti-freezer spheroidal cast iron.
- ✔ Chromium plated and casehardened pump shaft.
- ✔ Pressed blades made of hardened manganese-vanadium alloy steel.
- ✔ Hot galvanized suction cone with built-in valve.
- ✔ Widia mechanical seal or double oil seal (on request).

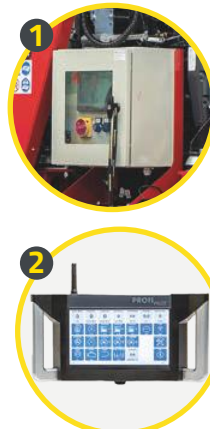

MEIER ELEKTRONIK AG
PROFI Pilot

Wireless Control System with 7" Touch Screen installed on the tractor/hauler to have a complete monitoring of speed, flow rate, status and much more.

Thanks to the wireless connection between pump and tractor the operator/final user can operate and monitor the entire system directly from the tractor.

System available in all **MOTOPOMPA Manure** Range.

CURVES

AFI 27

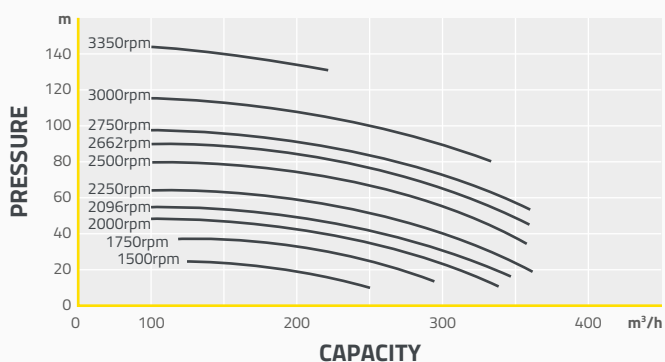

AFI 35

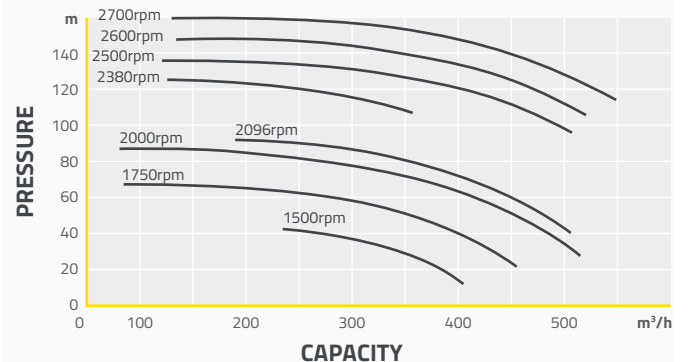

COMAP INTELIGEN 500 CONTROL UNIT. THE BRAIN INSIDE OUR MACHINES.

Comap IntelliGen 500 is the advanced control unit with a high resolution display and a wide variety of functions.

Connected to the WebSupervisor application in cloud, it offers GPS with complete and quick control of your pumps from any connected device. It allows to start and stop your pump set, monitor it and adjust settings from miles away.

INFOGRAPHIC MENU

- ✔ Pressure and vacuum, engine/motor revolutions, absorbed power and many others reported on digital meters in real time.
- ✔ Safe and unsafe operating ranges displayed in green and red colors, including warnings and protective actions.

NAVIGATION

- ✔ Smart software that makes navigation as simple as possible.
- ✔ Optimum graphic design displaying all major information.
- ✔ Intuitive command buttons with icons for easy identification.



STANDARD FUNCTIONALITIES AND MORE

- ✔ Pump / Engine protection.
- ✔ On/Off switch and PID control functions.
- ✔ Highly connected: pressure transducer, float switches, flow meter, electrovalves and much more.
- ✔ Events logger.

ALWAYS PROTECTED

- ✔ Maintenance program timer.
- ✔ Theft protection: based on fuel consumption or geofencing.

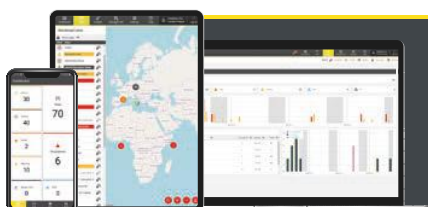

WEB SUPERVISOR.
FULL REMOTE CONTROL
OF THE PUMPING UNITS.



SPECIFIC PUMPING APPLICATIONS



AGRICULTURE

MOTOPOMPA & LAMPO AG SERIES

IRRIGATION

Arsura Diesel Series, from 3 to 12" with a wide range of flow & pressure, the ideal application for the new ComAp irrigation control unit designed by Euromacchine.



- ✓ PIPE FILLING FUNCTION
- ✓ AUTOMATIC PRIMING FUNCTION
- ✓ MONITORING WORKING PRESSURE
- ✓ MAINTENANCE TIMERS
- ✓ PUMP PROTECTIONS BY A WIDE RANGE OF CONNECTED SENSORS



MOTOPOMPA COMBI SERIES

LINEAR & PIVOT SYSTEMS

Hybrid Irrigation solution: diesel pump units able to satisfy a wide range of performance with the complete control of electric or hydraulic external sources thanks to the new Software installed in ComAp IG500.

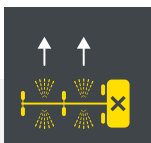

SUMMER MODE

Manages the complete pumping and movement supply system.

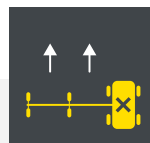

WINTER MODE

Allows movement of the pivot system without affecting the water pumping functions.

ADDED VALUE OVERVIEW. COMPANY HIGHLIGHTS.

Our machines reflect who we are. They are the competitive product of a family run business. Reliability, performance and customization: qualities that we are proud to represent in products designed and patented by Euromacchine.

Our business began over 40 years ago, yet we continue to bring to the equation that fresh energy and initial desire to seek out. This is precisely the spirit that has allowed us to grow and establish ourselves in the market.

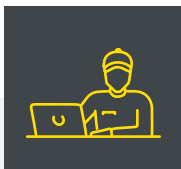

CONSULTANCY

Our experts will guide you to find the right solution for your agricultural field size and the required flow rate.



PRODUCTION

Each machine is manufactured with meticulous craftsmanship, by assembling exclusively the best components on the market.



ASSISTANCE

We remain at your side for any needs: from installation to assistance during the whole irrigation season.



STOCKING AREA & JUST-IN-TIME EQUIPMENT

+5.000 sqm

of warehouse area

+15.000

items available



PRODUCTION LINE

7 ASSEMBLY-AREAS

LEAN manufacturing methods

1 TEST ROOM

All Euromacchine units
are 100% tested

**Pump
Academy**

Euromacchine Pump Academy is held by our technicians who share their experience and show the best way to analyze the problem and find the right solution.



During the lessons, you may access our Test Area where we test all the assembled machines and check water pressure parameters.

CONTACT US AT info@euromacchine.it





Euromacchine S.r.l.
Via dell'Artigianato, 38
31047 Ponte di Piave (TV) - Italy

 (+39) 0422 149 86
 info@euromacchine.it

www.euromacchine.com